

**WEFLO**<sup>®</sup>  
**WEFLO VALVE LLC**

## COMPANY PROFILE

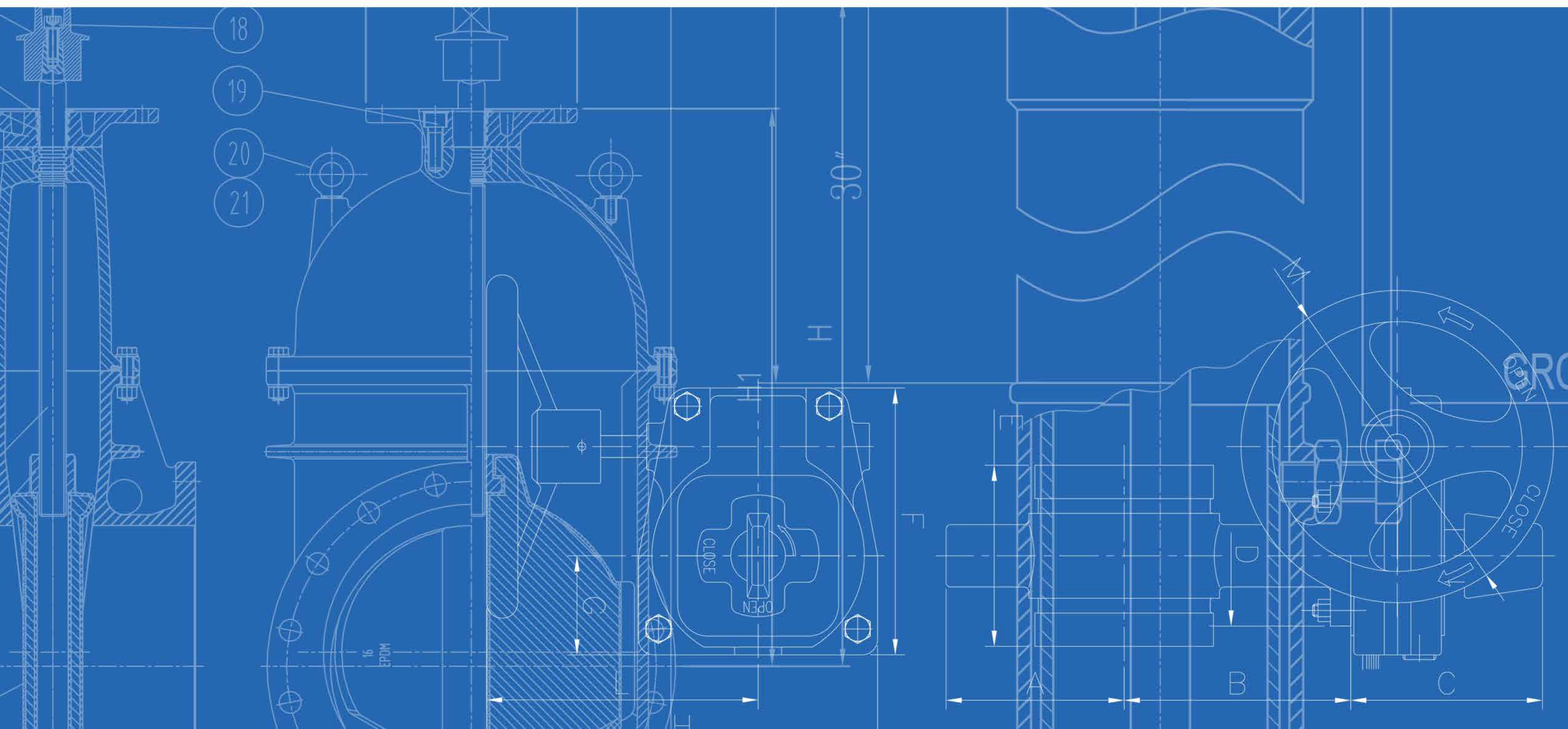



## CONTENTS

- 01 ABOUT WEFLO**
- 02 PRODUCT TESTING AND DESIGN**
- 03 THIRD PARTY CERTIFICATION**
- 04 MAJOR PRODUCT LINES**
- 05 MARKETING AND DISTRIBUTION**
- 06 COMPANY LOCATIONS**

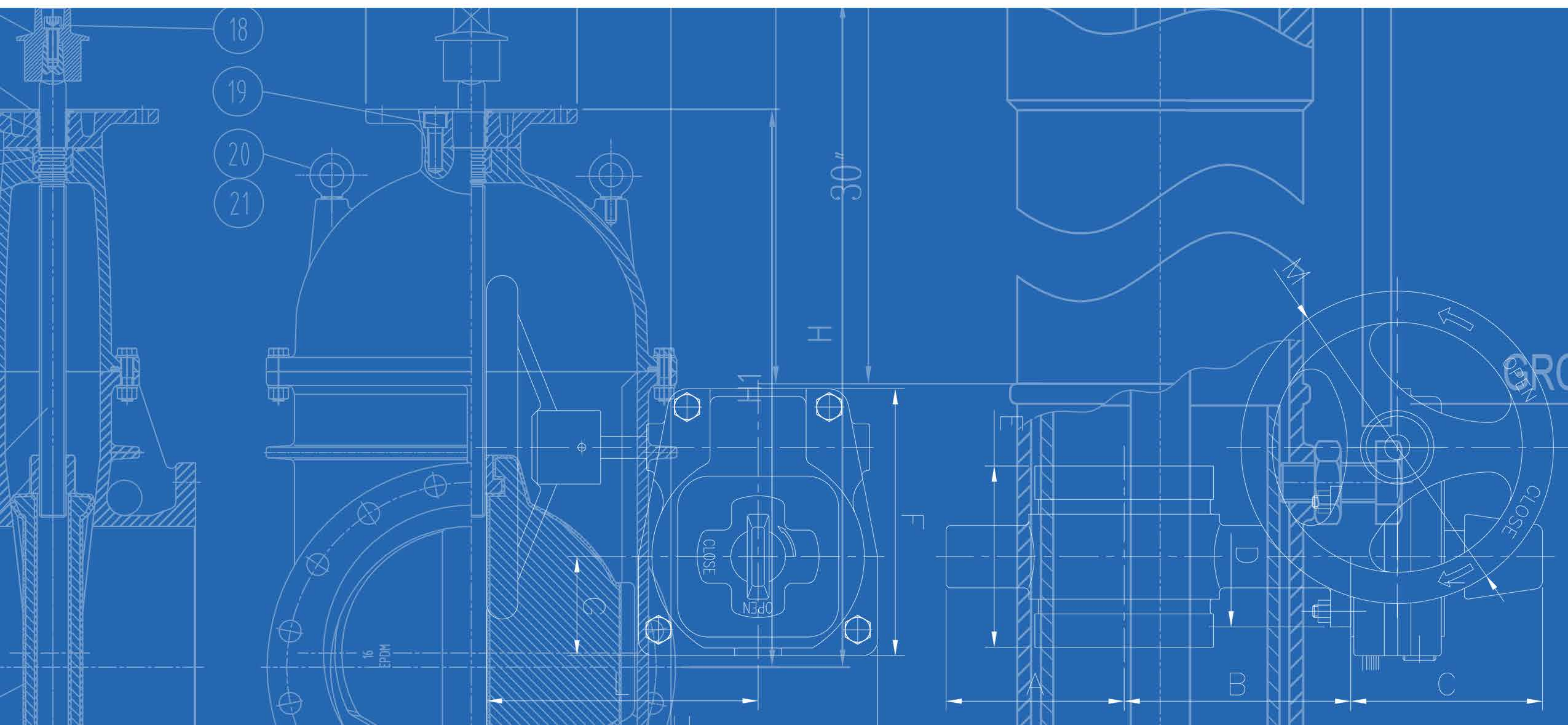

# WEFLO<sup>®</sup>

WEFLO VALVE LLC



## ABOUT WEFLO

Weflo Valve LLC is a wholly owned subsidiary of the Weflo Valve Co., Ltd.

Weflo Valve Co., Ltd. specializes in the design and manufacture of valve and fire hydrant products for the world-wide fire protection, waterworks, HVAC, and industrial markets.

Founded in 1992 as the Weilong Valve Co., Ltd. (the name was formally changed to Weflo Valve Co., Ltd. in January, 2015 to recognize our "WEFLO" brand of products and consolidate our companies); the company is vertically integrated to include all aspects of manufacturing. From our state of the art foundry, with CNC pattern making equipment, to our automated Fusion Bonded Epoxy Coating line, we control each and every aspect of our manufacturing processes. This allows us to offer the highest quality valve and hydrant products, on the most consistent basis, to our customers around the world.

The main Weflo Valve Co., Ltd. manufacturing facility covers more than 65,000 square meters and employs some 930 workers. This facility is ISO 9001:2008 Certified.

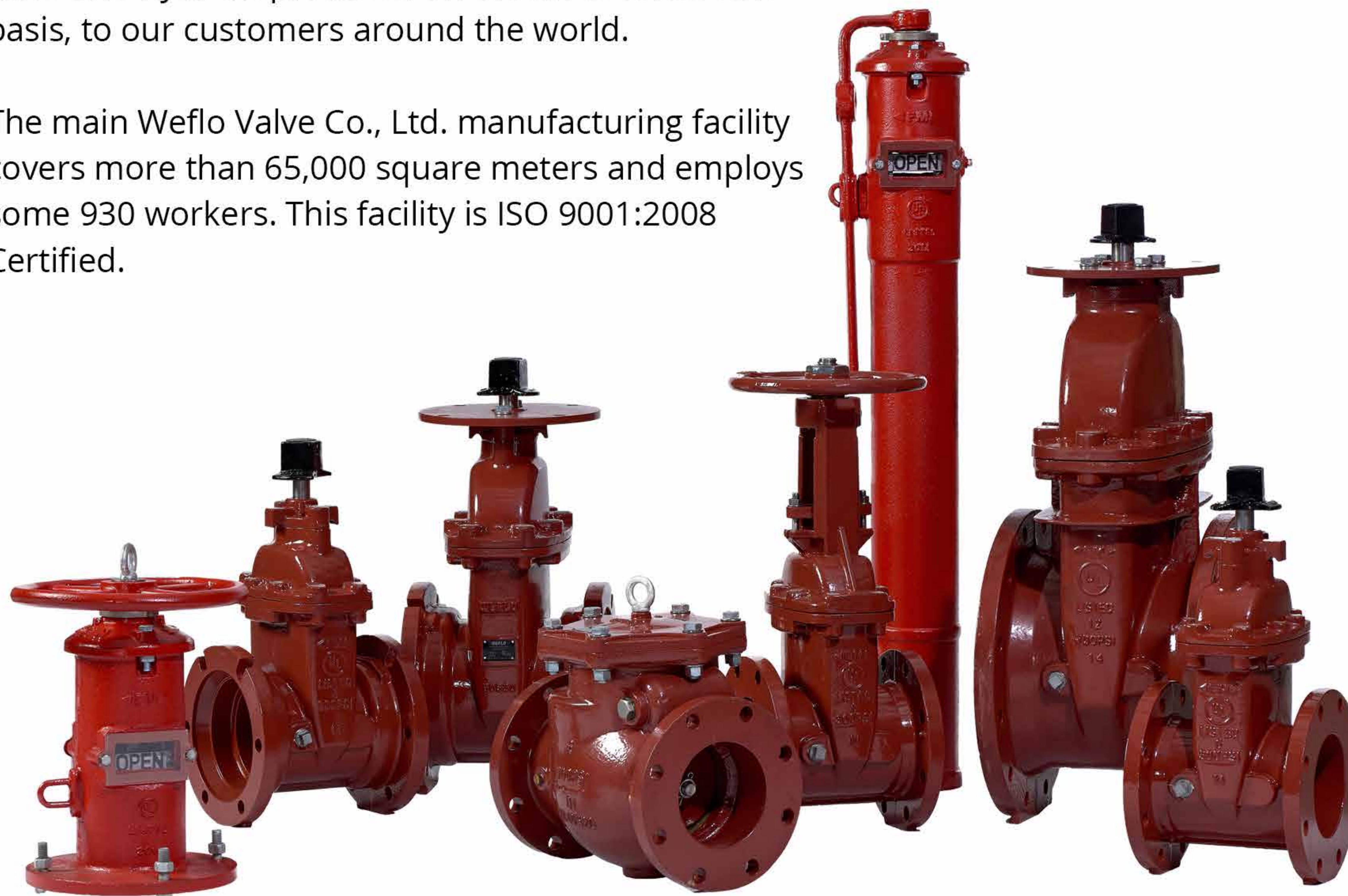



# PRODUCT TESTING AND DESIGN

Weflo Valve Co., Ltd. operates one of the most extensive and best equipped valve testing laboratories in the world. We conduct closed loop flow testing, discharge (head loss) testing, hydrostatic testing, and metallurgical testing on a continual basis. Our testing laboratory works directly with our manufacturing department to test 100% of all production lots to the appropriate industry standards. Further, our testing laboratory allows our research and development department to continually improve on existing or new product designs.

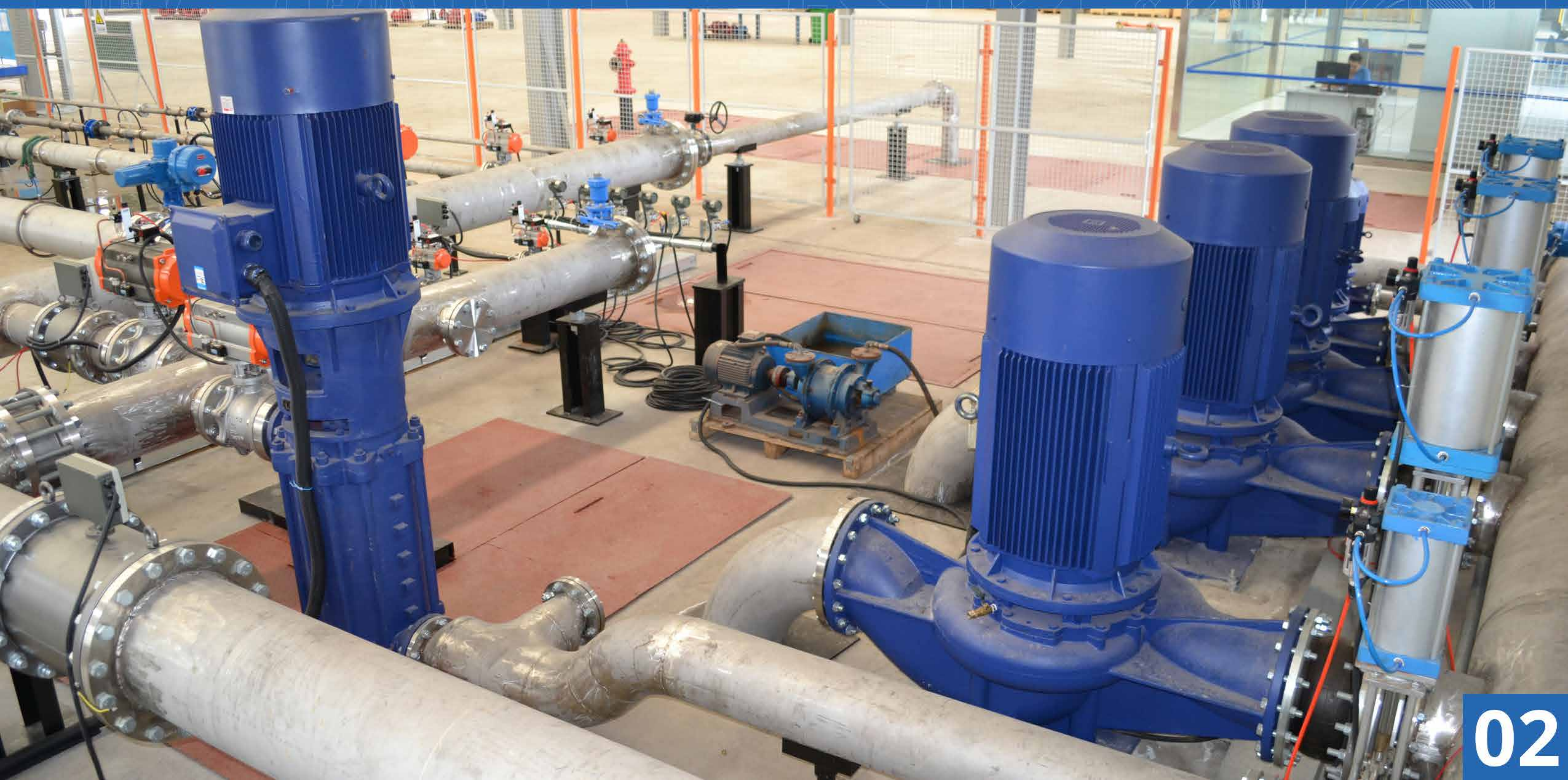

Item No.	Q'ty (PCS)	Description	Class	Size	Material								UL 262		Air Test	Result
					Body				Bonnet				Body	Seat	Seat	
1	30	AWWA C515-09 Model F0211 FM & UL • DI Body NRS Resilient Seat Gate Valve	300PSI	DN80	ASTM A536-84 (2009) 65-45-12				ASTM A536-84 (2009) 65-45-12				42.0 bar	32.0 bar	N/A	OK

Item No.	Order No.:	Name of Part	Heat No.	Chemical Composition(%)										Mechanical Properties			
				C	Si	Mn	P	S	Cr	Ni	Mo	Cu	V	Tensile Strength (MPa)	Yield Point (MPa)	Elongation%	HB
1	#072514	Body	L0718	3.64	2.63	0.22	0.010	0.006	N/A	N/A	N/A	N/A	N/A	537	377	13.6	N/A
			N140715	3.66	2.67	0.30	0.008	0.006	N/A	N/A	N/A	N/A	N/A	530	366	14.3	N/A
		Bonnet	N140713	3.65	2.64	0.24	0.008	0.006	N/A	N/A	N/A	N/A	N/A	538	359	13.9	N/A
			N140716	3.69	2.66	0.22	0.009	0.008	N/A	N/A	N/A	N/A	N/A	532	362	14.2	N/A

# THIRD PARTY CERTIFICATION

In addition to our own in-house testing, Weflo Valve Co., Ltd. continually tests its products at industry recognized laboratories around the world. We maintain one of the broadest ranges (at the highest rated pressures) of Third Party Certifications, Listings, and Approvals available from any manufacturer. These include:

- Underwriters Laboratories
- Factory Mutual Hydraulics Laboratory
- CE
- WRAS
- NSF International (Lead-Free)
- Australian Watermark
- Australian Gas Association



All of our products are provided with full Material Test Reports and documentation of quality assurance, and all of our Third Party Certification Documents are available upon request.

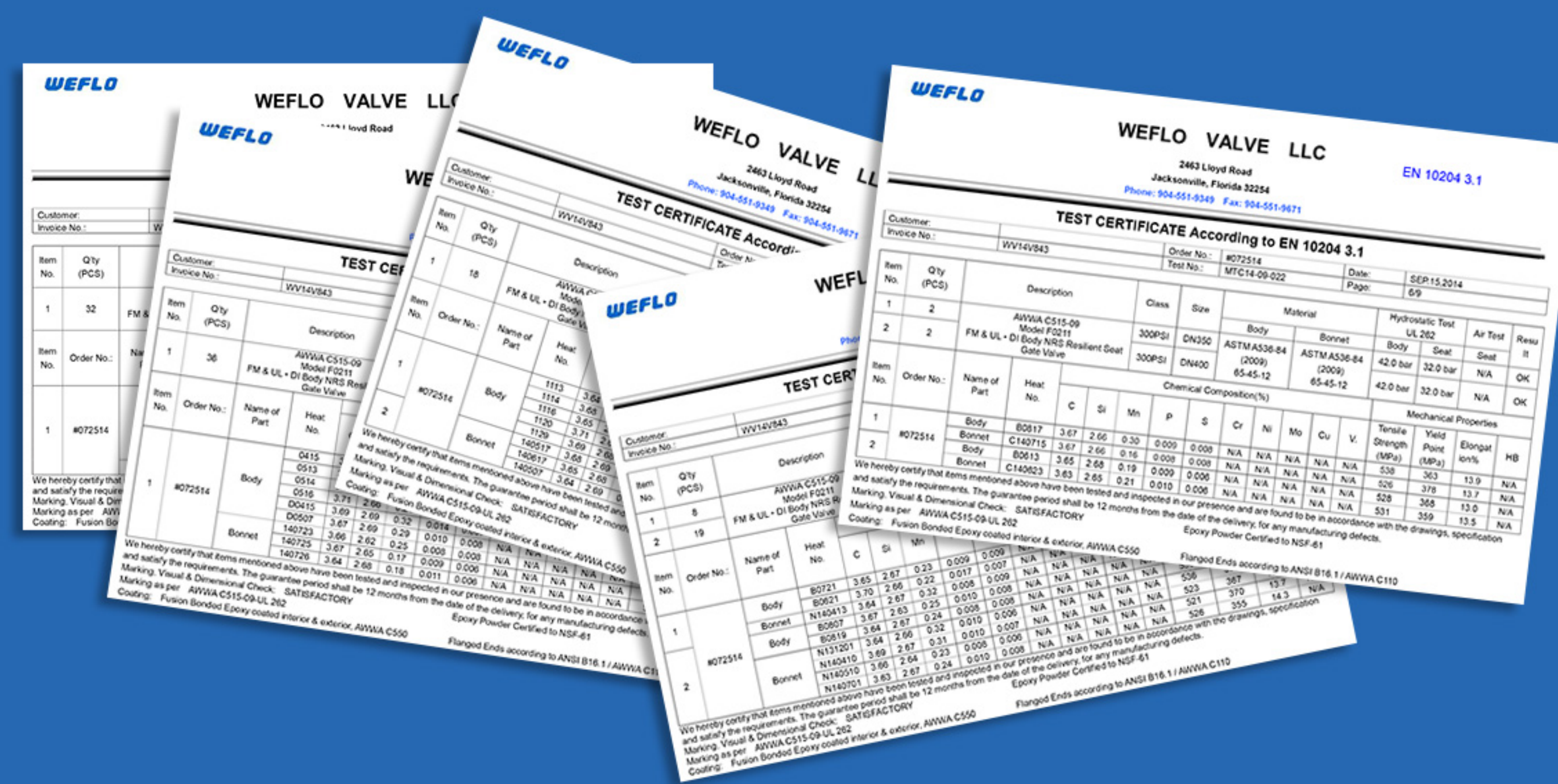

Our UL / FM Fire Protection products are manufactured to meet all applicable NFPA Standards.





## MAJOR PRODUCT LINES

Weflo Valve Co., Ltd. offers a full line of valve and hydrant products, including:

- Dry Barrel Fire Hydrants. American Water Works Standard C502. UL Listed / FM Approved.
- Wet Barrel Fire Hydrants. American Water Works Standard C503. UL Listed / FM Approved.
- Resilient Seated Post Indicator Gate Valves. UL Listed / FM Approved.
- UL / FM Vertical Indicator Posts. UL / FM Wall Indicator Posts
- Large Diameter Resilient Seated Post Indicator Valves. UL Listed in sizes through 24", at the highest rated pressure in the world.
- UL Listed Vertical Indicator Posts with Built-In Gear Drive. Sizes through 24".
- UL / FM Swing Check Valves.
- UL / FM Wye Strainers and Basket Strainers
- AWWA C500, AWWA C509, AWWA C515 Gate Valves
- Globe Valves, Wafer Check Valves, Foot Valves, Suction Diffusers
- AWWA Butterfly Valves
- UL / FM Butterfly Valves (with supervisory switch)





# MARKETING AND DISTRIBUTION

Weflo Valve Co., Ltd. manufactures, under private label, for OEM accounts around the world.

We also manufacture products under our own brand name "WEFLO". These are sold through a network of stocking distributors around the world.





## COMPANY LOCATIONS

### EUROPE, MIDDLE EAST, AFRICA MARKET

Contact: [info@weflovalve.com](mailto:info@weflovalve.com)  
Weflo Valve Co., Ltd.  
145-157 St. John Street  
London, EC1V 4PY  
United Kingdom

### MANUFACTURING & ASIA – PACIFIC MARKET

Contact: [info@weflovalve.com](mailto:info@weflovalve.com)  
Weflo Valve Co., Ltd.  
Intersection of Huadong Road and Chunyang Road  
Qingdao National High-Tech Development Zone  
China 266111

### AMERICAS

Contact: [sales@weflo.com](mailto:sales@weflo.com)  
Weflo Valve LLC  
2463 Lloyd Road  
Jacksonville, Florida 32254  
USA

