

## Pressure Switch with Retard

## FIG. WPSR

### Features

- Equipped with tamper resistant screws to prevent unauthorized entry.
- Built-in mechanical time delay feature to prevent false alarms due to water pressure variation.
- Enclosure:
  - Cover: Die cast, Aluminum Alloy, ASTM B 85 A04130
  - Finish: Red powder coat
  - Base: Die cast, Aluminum Alloy, ASTM B 85 A04130
  - All parts have corrosion resistant finishes.
- Maximum Pressure: 300psi
- Pressure Range: 5-8 psi(0.3-0.55bar) on rising pressure
- Contact Rating: Two sets of SPDT; 10A @ 125/250VAC, 3A @ 24VDC.
- Pressure Connection: 1/2" male NPT
- Operating Temperature Range: -40°C to 60°C
- Conduit Entrances: one knockouts and one hole for 1/2" conduit provided
- Weight: 0.8kg
- UL Listed, FM Approved, EAC and CE Certified

### Schematic & Dimensions (mm / Inch)

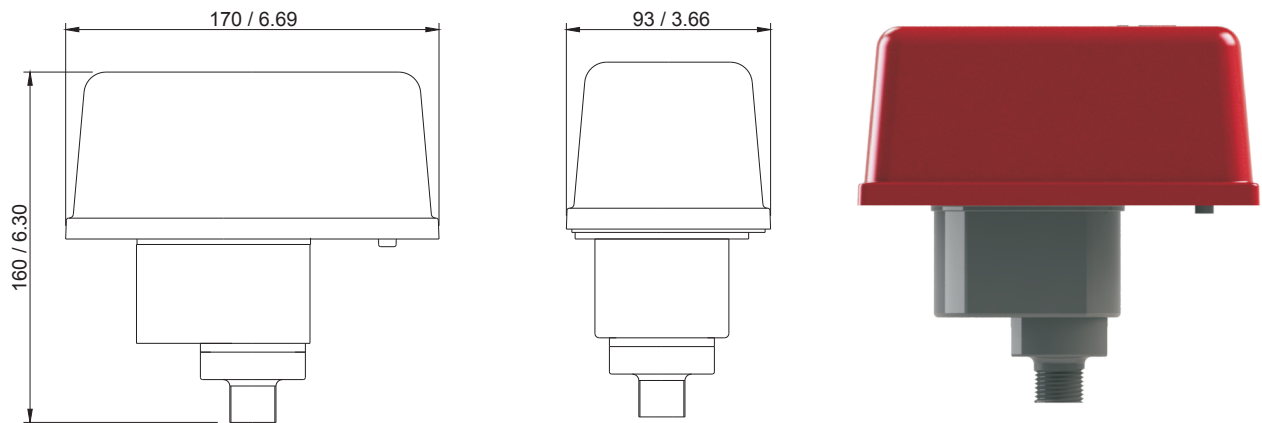

### Typical Connections

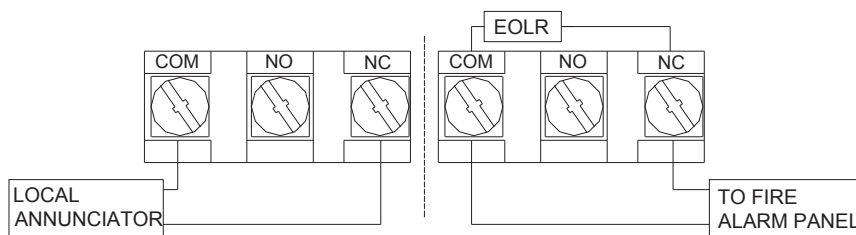

outgoing incoming

An uninsulated section of a single conductor should not be looped around the terminal and serve as two separate connections

#### Note

• Designs, materials and specifications shown are subject to change without notice due to the continuous development of our products.