

Item No.	Description	Material	Specification	Qty. Req'd
1	Body	DI	ASTM A536 65-45-12	1
2	Chain	Carbon Steel		3
3	Nozzle Cap	Cast Iron		1
4	Pumper Nozzle	Bronze	ASTM B62	1
5	Pumper Nozzle Gasket	NBR		1
6	Main Valve	NBR		1
7	Main Valve Retainer	Bronze	ASTM B62	1
8	Screw M5x10	SS304		3
9	Main Valve Holder	SS304		1
10	Holder Nut	Bronze	ASTM B62	3
11	Lock Washer	SS304		3
12	Stem-A	SS304		1
13	Hose Nozzle Cap	CI	ASTM A126	2
14	Hose Nozzle Gasket	NBR		2
15	Hose Nozzle	Bronze	ASTM B62	2
16	Main Valve Retainer	Bronze	ASTM B62	2
16a	Main Valve	NBR		2
17	Main Valve Holder	SS304		2
18	Stem-C	SS304		1
19	Stem Nut	Bronze	ASTM B62	2
20	Operating Nut	Bronze	ASTM B62	3
21	Nut	SS304		3
22	O-ring	NBR		6
23	Stem Nut	Bronze	ASTM B62	1
24	O-ring	NBR		3
25	O-ring	NBR		1
26	O-ring	NBR		2
27	Stem-B	SS304		1

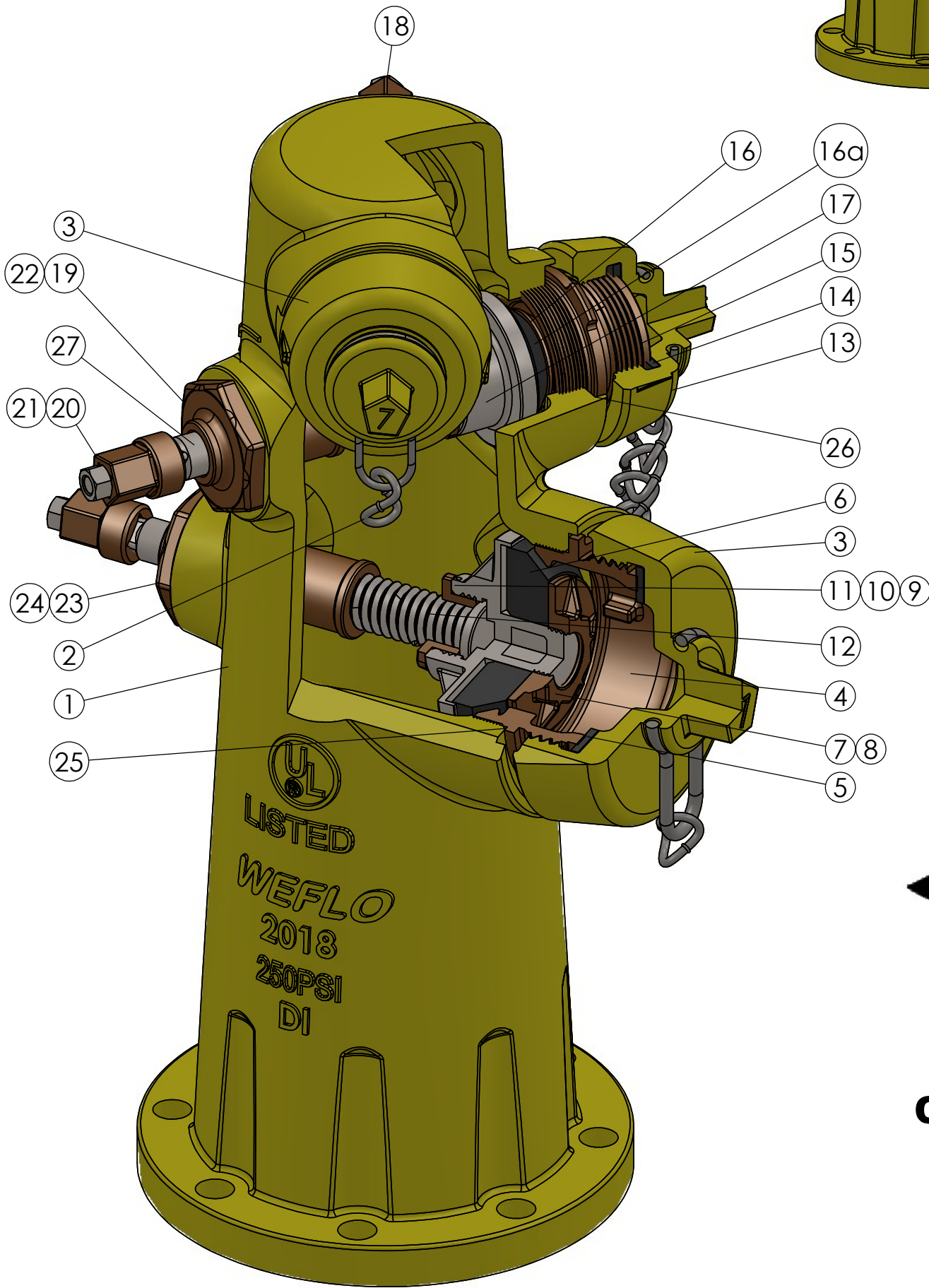
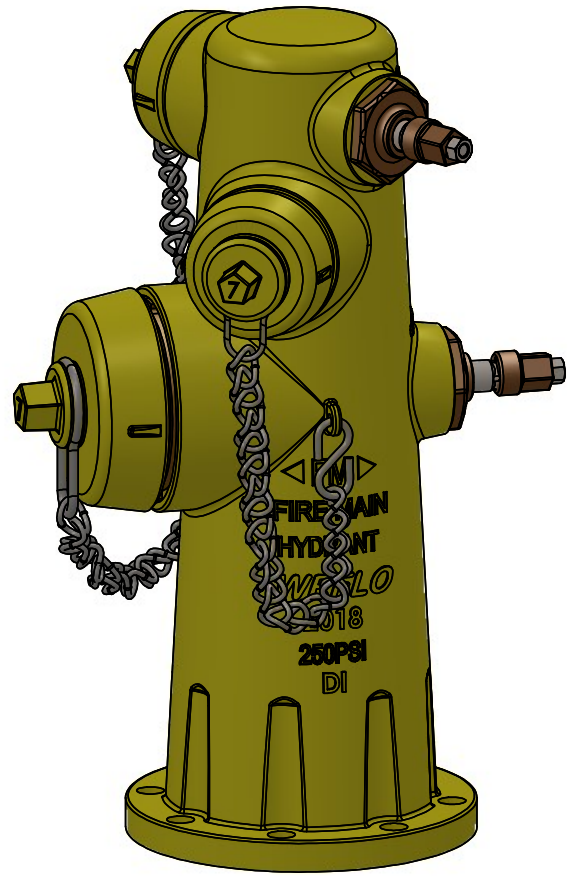

Notes:

- Design and materials are able to change without prior verbal or written notification.
- Pressure rating: UL Listed 250 PSI; FM Approved 250 PSI.
- Temperature rating: -10°C to 82°C.
- Monitor Outlet, Storz, and other nozzles also available.
- Coating: Interior and exterior e-coated to 6 mils min. dry film thickness, then fusion bonded epoxy coated (FBE).
- Hydrant to be in accordance with AWWA C503.
- Nozzle threads to be in accordance with NFPA 1963 for standard fire hose coupling screw thread. Pumper nozzle threads: 4.5-4NH; hose nozzle threads: 2.5-7.5NH.
- Flange to be in accordance with ANSI B16.1 class 125.

CONFIDENTIAL & PROPRIETARY INFORMATION		WEFLO®		NAME	DATE
<small>THE DATA CONTAINED IN THIS DRAWING IS THE SOLE PROPERTY OF WEFLO VALVE LLC. ANY REPRODUCTION IN PART OR AS A WHOLE WITHOUT THE WRITTEN PERMISSION OF WEFLO VALVE LLC IS PROHIBITED.</small>		<b>TITLE: WEFLO Wet Barrel Fire Hydrant AWWA C503 8-hole Flange / 2H1P Safety Yellow</b>		ENGINEER/DRAFTSMAN	BCM
				1st CHECK	
				2nd CHECK	
				3rd CHECK	
UNLESS OTHERWISE SPECIFIED: DIMENSIONS ARE IN INCHES		REVISION		DATE	
MATERIAL		A	INITIAL ISSUE	5/16/18	BM
WEIGHT		DWG. NO.		AF00015	
FINISH		SCALE: NONE - UNLESS NOTED		REVISION <b>A</b>	
DO NOT SCALE DRAWING				SHEET 1 OF 1	