

## OS&Y Resilient Seated Gate Valve FL x FL Ends, 200PSI/250PSI Size 14"–24" FIG · F1111–200/F1111-250

### Specifications

- Complies with AWWA C515 Standard.
- Heavy duty handwheel and attachment nut.
- Flange end to ANSI B16. 1 Class125.  
(Other flange types available upon request)
- NPT plug on body(optional).
- Eye-Bolts on bonnet for ease of handling.
- UL/ULC Listed and FM Approved
- Certified to NSF/ANSI 61 & 372.

### Working Pressure

- 250PSI for 14"–16"–18".
- 200PSI for 20"–24".

### Working Temperature

- -10°C to 120°C.

### Corrosion Protection

- Fusion Bonded Epoxy Coated Interior and Exterior to AWWA C550 Standard.

### Notes:

- Design and material are subject to change without notice.
- Stem Material: should be changed to SS304, option SS316 and other series 300 stainless steel, Bronze.

### Material Specifications

No.	Part Name	Material
1	Body	Ductile Iron, A536 65-45-12
2	Wedge	Ductile Iron A536 65-45-12, EPDM Encapsulated
3	Wedge Nut	B148 C95200
4	Stem	Stainless Steel, A276 UNS S30400
5	O-Ring	EPDM
6&7&8	Bolt & Washer & Nut	Carbon Steel, Zinc Plated
9	Bonnet	Ductile Iron, A536 65-45-12
10	Packing	Graphite
11	Packing Bushing	Brass
12&13	Bolt & Washer	Carbon Steel, Zinc Plated
14	Handwheel supporter	Ductile Iron, A536 65-45-12
15	Stem Nut	Brass
16	Stem Nut Washer	Brass
17	Lock Nut	Carbon Steel, Chrome Plated
18	Handwheel	Ductile Iron, A536 65-45-12
19	Set Screw	Carbon Steel, Zinc Plated
20	Handwheel Nut	Ductile Iron, A536 65-45-12
21&22	Stud & Washer	Carbon Steel, Zinc Plated
23	Packing Gland	Ductile Iron, A536 65-45-12
24	Eye Bolt	Carbon Steel, Zinc Plated
25	O-Ring	EPDM
26	Pin	Stainless Steel, AISI 420
27	NPT Plug	Malleable Iron, Zinc Plated

### Schematic

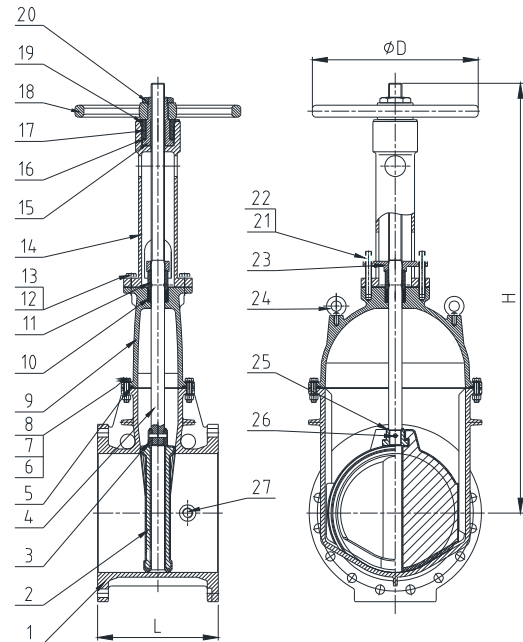
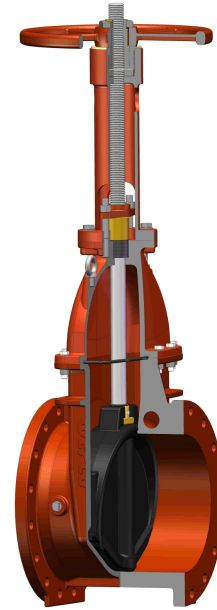

### Dimensions (mm)

Size	350	400	450	500	600
L	381	406	432	457	508
H (Open)	1574	1786	2020	2276	2600
H (Close)	1224	1386	1570	1776	2000
D	445	535	610	610	762