

Item No.	Description	Material	Specification	Qty. Req'd
1	Operating Nut	Bronze	ASTM B62 C83600	1
2	Hold Down Nut	Bronze	ASTM B584	1
3	Hold Down Nut O-Ring	Rubber	ASTM D2000, BUNA N	1
4	Weather Seal	Rubber	ASTM D2000, BUNA N	1
5	Bonnet O-Ring	Rubber	ASTM D2000, BUNA N	1
6	Anti-Friction Washer	Celcon	Celcon	1
7	Oil Plug	Bronze	ASTM B16 C36000	1
8	Bonnet	Cast Iron	ASTM A126, CL-B	1
9	Bonnet Bolts & Nuts	Steel	ZPS, A307	8
10	Bonnet O-Ring	Rubber	ASTM D2000, BUNA N	1
11	Upper Rod	Steel	ASTM A576, Gr-B	1
12	Upper Rod O-Ring	Rubber	ASTM D2000, BUNA N	2
13	Nozzle Lock Key	Stn. Stl.	ASTM A276	6
14	Pumper Nozzle	Bronze	ASTM B62 C83600	1
15	Pumper Nozzle Gasket	Rubber	ASTM D2000, BUNA N	1
16	Pumper Nozzle O-Ring	Rubber	ASTM D2000, BUNA N	1
17	Pumper Nozzle Cap	Cast Iron	ASTM A126, CL-B	1
18	Hose Nozzle	Bronze	ASTM B62 C83600	2
19	Hose Nozzle Gasket	Rubber	ASTM D2000, BUNA N	2
20	Hose Nozzle O-Ring	Rubber	ASTM D2000, BUNA N	2
21	Hose Nozzle Cap	Cast Iron	ASTM A126, CL-B	2
22	Cap Chain	Steel	Zinc Plated	3
23	Chain Ring	Steel	Zinc Plated	3
24	Standpipe Upper	Ductile Iron	ASTM A536 65-45-12	1
25	Safety Coupling	Stn. Stl.	ASTM A890	1
26	Safety Flange Bolts & Nuts	Steel	ZPS, A307	8
27	Safety Flange O-Ring	Rubber	ASTM D2000, BUNA N	1
28	Safety Flange	Cast Iron	ASTM A126, CL-B	2
29	Cotter Pin	Stn. Stl.	ASTM A276	2
30	Clevis Pin	Stn. Stl.	ASTM A276	2
31	Lower Rod	Steel	ASTM A576 Gr-B	1
32	Standpipe Lower (Specify Bury)	Ductile Iron	ASTM A536 65-45-12	1
33	Stem Pin	Stn. Stl.	ASTM A276	2
34	Drain Valve Facing	HDPE	-	2
35	Drain Valve Screw	Stn. Stl.	ASTM A276	4
36	Valve Top Plate	Bronze	ASTM B584	1
37	Elbow & D.R.H. Bolts & Nuts	Stn. Stl.	ZPS, A307	6
38	Drain Ring Housing O-Ring	Rubber	ASTM D2000, BUNA N	1
39	Seat Ring O-Ring (Top)	Rubber	ASTM D2000, BUNA N	1
40	Drain Ring Housing	Cast Iron	ASTM A126, CL-B	1
42	Drain Ring	Bronze	ASTM B584	1
43	Seat Ring	Bronze	ASTM B584	1
44	Seat Ring O-Ring (Bottom)	Rubber	ASTM D2000, BUNA N	1
45	Main Valve	Rubber	ASTM D2000, BUNA N	1
46	Valve Bottom Plate	Ductile Iron	ASTM A536 65-45-12	1
47	Cap Nut Seal	Rubber	ASTM D2000, BUNA N	1
48	Lock Washer	Stn. Stl.	ASTM A276	1
49	Valve Bottom Plate Nut	Bronze	ASTM B584	1
50	Elbow	Ductile Iron	ASTM A536 65-45-12	1
51	Lubricant (in Chamber)	Mineral Oil	Food Grade	1

Monitor Connection Available in
2.5", 3" and 4" Configurations
ANSI B16.1 Class 125/150
(4" Monitor Connection Shown)

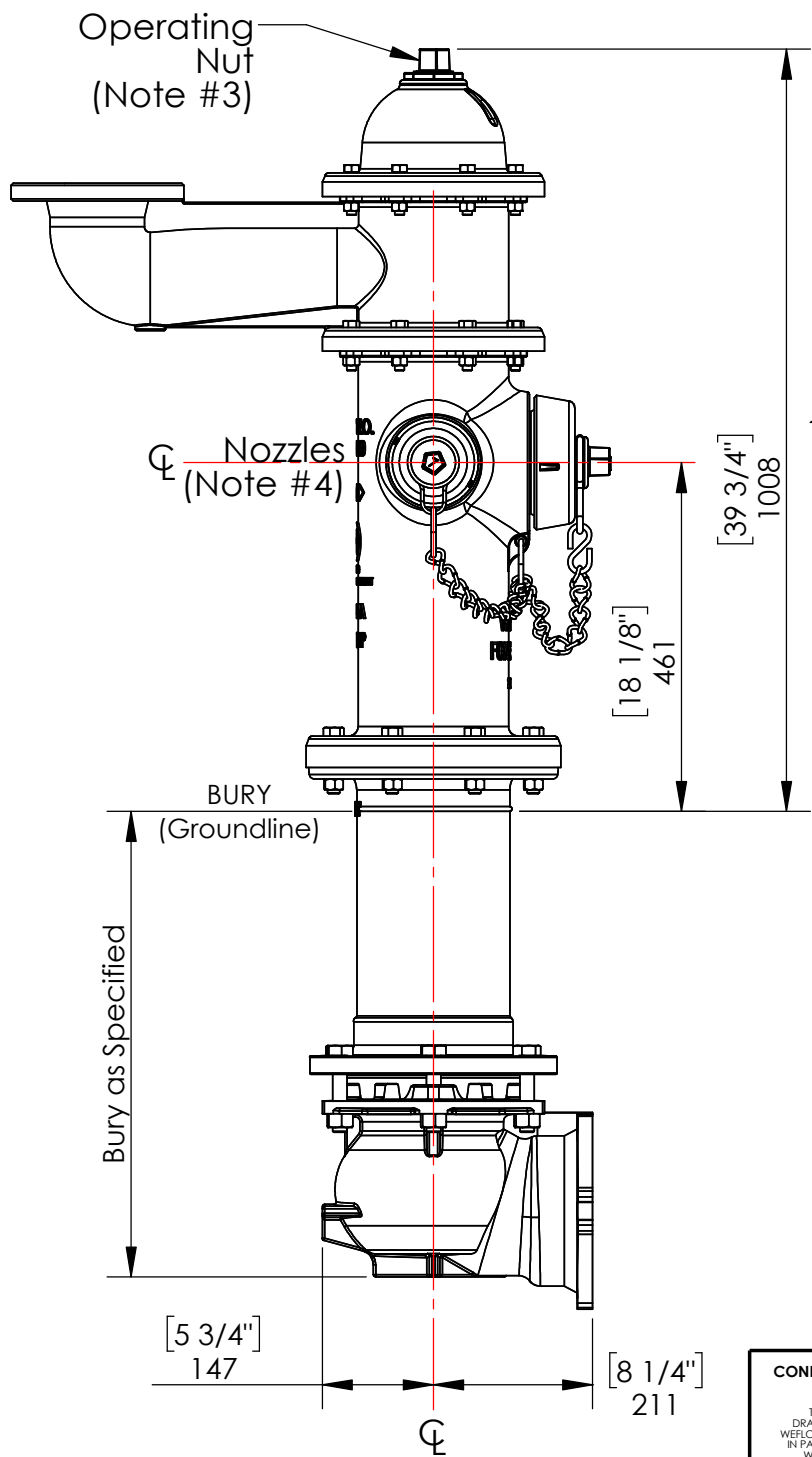
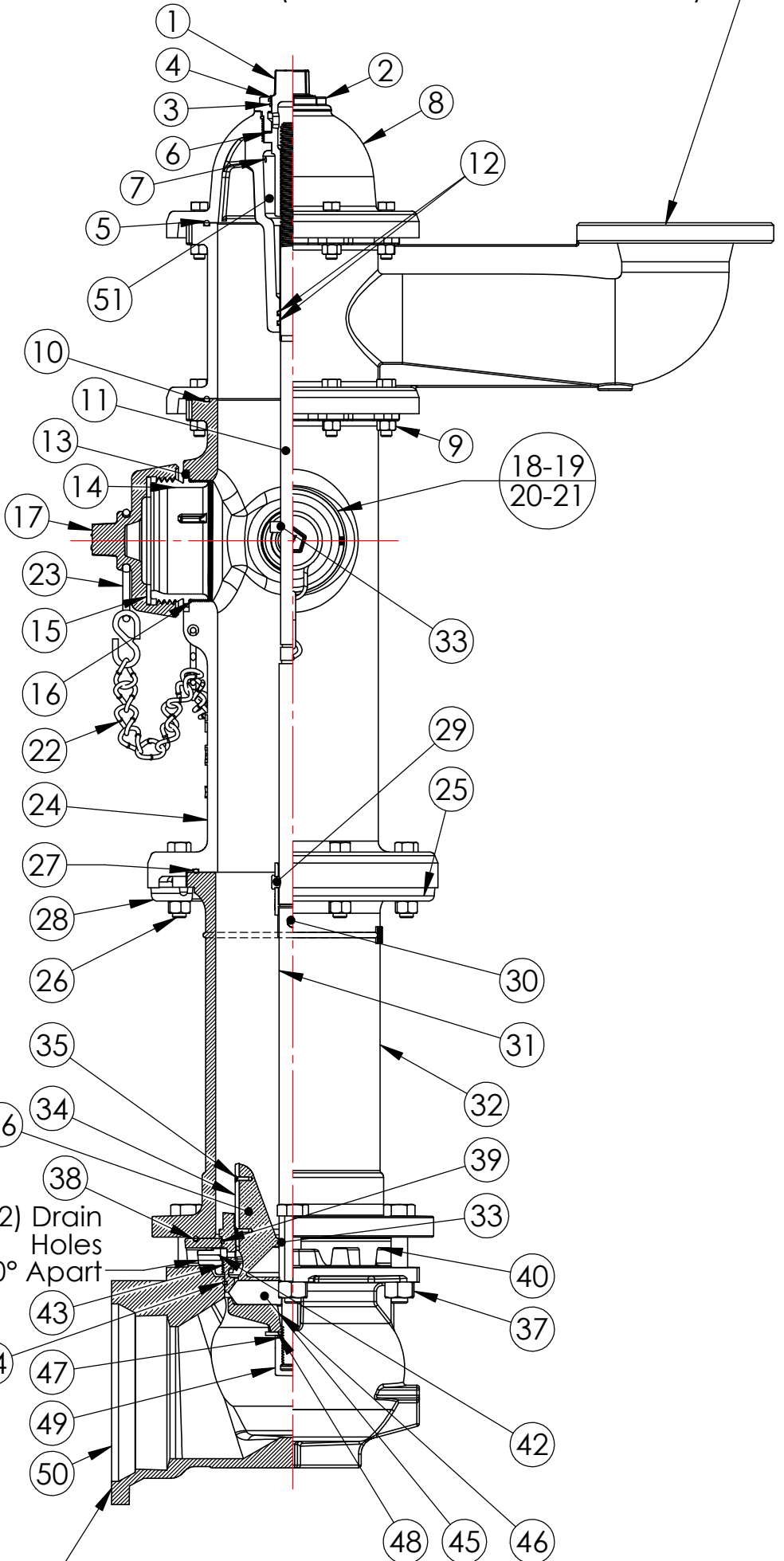

(2) Drain Holes
180° Apart

6" MJ Inlet per
ANSI/AWWA C111/A21.11

OPTIONAL: Flanged Elbow
Drilled to ANSI 125
or PN10/PN16

Notes:

- 1) Design and materials are able to change without prior verbal or written notification.
- 2) Pentagon measures 1 1/2" from point to flat at the base of the nut and 1 7/16" at the top; the min. height of the nut is 1".
- 3) Certain parts are Fusion Bonded Epoxy coated, inside and out, in accordance with AWWA C550 (#s 40, 46, 49 & 50).
- 4) Storz and other nozzles are also available.

CONFIDENTIAL & PROPRIETARY INFORMATION		WEFLO		NAME	DATE
THE DATA CONTAINED IN THIS DRAWING IS THE SOLE PROPERTY OF WEFLO VALVE LLC. ANY REPRODUCTION IN PART OR AS A WHOLE WITHOUT THE WRITTEN PERMISSION OF WEFLO VALVE LLC IS PROHIBITED.				ENGINEER/DRAFTSMAN	5/24/17
UNLESS OTHERWISE SPECIFIED: DIMENSIONS ARE IN INCHES		TITLE: WEFLO Dry Barrel Fire Hydrant (5 1/4") AWWA C502 Monitor Connection (Ductile Iron)		1st CHECK	
MATERIAL				2nd CHECK	
WEIGHT				3rd CHECK	
FINISH				4th CHECK	
DO NOT SCALE DRAWING				APPROVED	
		REVISION		DWG. NO.	
		A		AF00004	
		INITIAL ISSUE		5/24/17	
		DATE		BY	
				BM	
				REVISION	
				A	
				SCALE: NONE - UNLESS NOTED	
				SHEET 1 OF 1	